



AIR RELEASE VALVE



Air release valve can efficiently evacuate the air in the pipe to reduce the noise or the interference which causes by air.

Air release valve can only be installed vertically.

Installing air release valve at the highest part of pipe line will recommend.

- ▶ Valve Body Testing Pressure: 21 kgf/cm²
- ▶ Valve Seat Testing Pressure: 15 kgf/cm²
- ▶ Maximum Applied Pressure: 10 kgf/cm²
- ▶ Maximum Applied Temperature: 120° C ~ 130° C
- ▶ Materials of valve body: Cast Iron, Stainless Steel
- ▶ Applied Conditions: Water

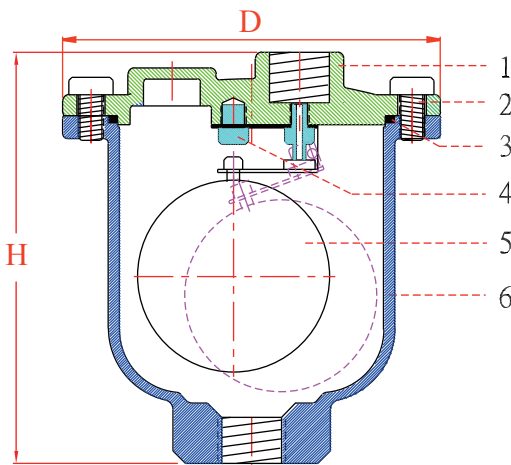

No	Part Name	Material	
1	Cover	Cast Iron	Stainless Steel
2	Fixed Bolt	Cast Iron	Stainless Steel
3	Sealing	Silicone	Silicone
4	Plug	Cast Iron	Stainless Steel
5	Float Ball set	Stainless Steel	Stainless Steel
6	Body	Cast Iron	Stainless Steel

Item No	Size	D(mm)	H(mm)	Weight(kg)
ATR-15-S	1/2"	120	131	2.5
ATR-20-S	3/4"	120	131	2.5
ATR-25-S	1"	120	131	2.5
ATR-40-S	1 1/2"	190	210	8.0
ATR-50-S	2"	190	210	8.0

Gate Full Open, Normal atmospheric temperature

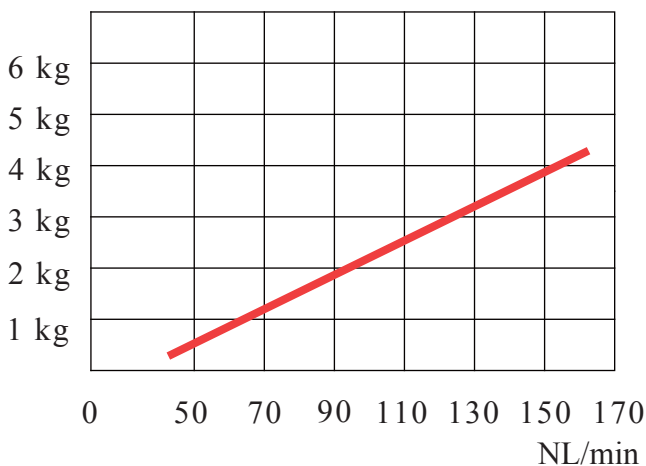

For 1 1/2" and 2" only available in Cast Iron

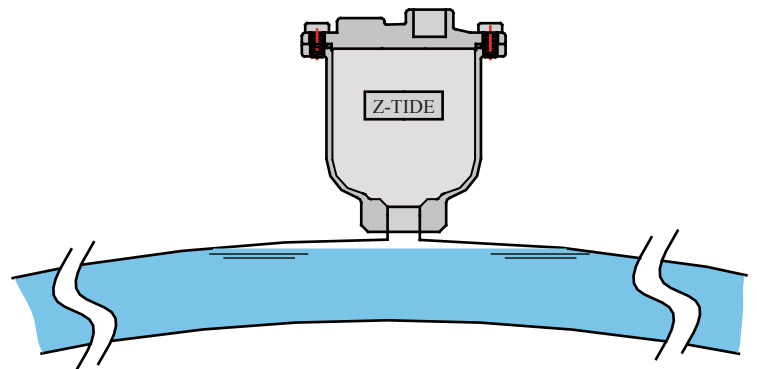

Installing air release valve at the pipe line where gather easily the air.